

**Digital Signal Processing**  
Homework Assignment Number 2 Solutions

Q1. The given  $H(z)$  has poles at  $z = 0.5$  and  $z = -0.25$ . Since, we are given that  $H(z)$  is defined at  $z = -0.125$ , then the region of convergence for  $H(z)$  must be the circular region with radius 0.25. Hence,  $h(n)$  must be an anti-causal sequence. (also, since the region of convergence does not include the unit circle, this must be an unstable sequence.) Hence, we need to find  $h(n)$  for  $n \leq 0$ . Use the “p” form:

$$H(1/p)p^{-n-1} = \frac{p^{-n}}{(1 - 0.5p)(1 + 0.25p)}.$$

We now use residues to calculate  $h(n)$ : Note that in terms of  $z$ , the integration contour will be a circle of radius less than 0.25 (to be inside the region of convergence). Hence, in terms of  $p$ , the contour will be a circle of radius greater than 4. Hence, both poles are included in the contour.

$$\begin{aligned} h(n) &= \text{Res} \left\{ \frac{-8p^{-n}}{(p-2)(p+4)}, 2 \right\} + \text{Res} \left\{ \frac{-8p^{-n}}{(p-2)(p+4)}, -4 \right\} \\ &= \frac{-8 \times 2^{-n}}{2+4} + \frac{-8 \times (-4)^{-n}}{-4-2} \\ &= -\frac{4}{3} \times 2^{-n} + \frac{4}{3} \times (-4)^{-n} \quad \text{for } n \leq 0 \end{aligned}$$

$h(n) = 0$  for  $n > 0$ .

Q2. Written in factored form, we have

$$H(z) = \frac{z+3}{(z+.2+.5j)(z+.2-.5j)}$$

Since,  $h(n)$  is stable and both poles are in the unit circle,  $h(n)$  must be causal. Hence, we calculate  $h(n)$  for  $n \geq 0$  using the  $z$ -form of the contour integration method; ie, for  $n > 0$ ,

$$\begin{aligned} h(n) &= \text{Res} \left\{ \frac{(z+3)z^{n-1}}{(z+.2+.5j)(z+.2-.5j)}, -.2+.5j \right\} + \text{Res} \left\{ \frac{(z+3)z^{n-1}}{(z+.2+.5j)(z+.2-.5j)}, -.2-.5j \right\} \\ &= \frac{(-.2+.5j+3)(-.2+.5j)^{n-1}}{(-.2+.5j+.2+.5j)} + \frac{(-.2-.5j+3)(-.2-.5j)^{n-1}}{(-.2-.5j+.2-.5j)} \\ &= \frac{(2.8+.5j)(-.2+.5j)^{n-1} - (2.8-.5j)(-.2-.5j)^{n-1}}{j} \\ &= \frac{2.8443e^{j \times 0.1767} 0.5385^{n-1} e^{j \times 1.9513(n-1)} - 2.8443e^{-j \times 0.1767} 0.5385^{n-1} e^{-j \times 1.9513(n-1)}}{j} \\ &= \frac{2.8443 \times 0.5385^{n-1} [e^{j \times 0.1767} e^{j \times 1.9513(n-1)} - e^{-j \times 0.1767} e^{-j \times 1.9513(n-1)}]}{j} \\ &= 5.6886 \times 0.5385^{n-1} \sin[1.9513(n-1) + 0.1767] \end{aligned}$$

Also, for  $n = 0$ , we have an extra pole at the origin. This pole contributes the term

$$\begin{aligned} &\text{Res} \left\{ \frac{(z+3)z^{-1}}{(z+.2+.5j)(z+.2-.5j)}, 0 \right\} \\ &= \frac{3}{(.2+.5j)(.2-.5j)} \\ &= 10.3448 \end{aligned}$$

Hence

$$\begin{aligned} h(0) &= 10.3488 + 5.6886 \times 0.5385^{-1} \sin[-1.9513 + 0.1767] \\ &= 0 \end{aligned}$$

Q3. First note that since  $H(z)$  has poles on the unit circle, it cannot be stable. We form the partial fraction expansion

$$\begin{aligned} \frac{H(z)}{z} &= \frac{z^2 - 0.4z + 0.68}{z(z-1)^2(z-0.8)} \\ &= \frac{a_{-1}^1}{z-0.8} + \frac{a_{-1}^2}{z-1} + \frac{a_{-2}^2}{(z-1)^2} + \frac{a_{-1}^3}{z} \end{aligned}$$

where

$$\begin{aligned} a_{-1}^1 &= \frac{.8^2 - 0.4 \times .8 + 0.68}{.8(.8-1)^2} = 31.2500 \\ a_{-1}^2 &= \left. \frac{d}{dz} \frac{z^2 - 0.4z + 0.68}{z(z-0.8)} \right|_{z=1} \\ &= \left. \frac{(z^2 - 0.8z)(2z - 0.4) - (z^2 - 0.4z + 0.68)(2z - 0.8)}{(z^2 - 0.8z)^2} \right|_{z=1} \\ &= \frac{(1 - 0.8)(2 - 0.4) - (1 - 0.4 + 0.68)(2 - 0.8)}{(1 - 0.8)^2} = -30.4000 \\ a_{-1}^2 &= \frac{1 - 0.4 + 0.68}{(1 - 0.8)} = 6.4000 \\ a_{-1}^3 &= \frac{0.68}{(-1)^2(-0.8)} = -0.8500 \end{aligned}$$

Thus,

$$H(z) = \frac{31.2500z}{z-0.8} - \frac{30.4000z}{z-1} + \frac{6.4000z}{(z-1)^2} - 0.8500$$

and therefore using the table of standard z-transforms

$$h(n) = [31.2500 \times 0.8^n - 30.4000 + 6.4000n]u(n) - 0.8500\delta(n)$$

Q4. Take unilateral z-transform of both sides:

$$Y_{ul}(z)(1 - 1.6z^{-1} + 0.89z^{-2}) - 1.6y(-1) + 0.89[y(-2) + z^{-1}y(-1)] = \frac{1 - z^{-5}}{1 - z^{-1}}$$

Hence

$$\begin{aligned} Y_{ul}(z) &= \frac{1.6 \times 5 - 0.89[4 + z^{-1}5] + \frac{1-z^{-5}}{1-z^{-1}}}{1 - 1.6z^{-1} + 0.89z^{-2}} \\ &= \frac{4.4400 - 4.45z^{-1} + \frac{1-z^{-5}}{1-z^{-1}}}{1 - 1.6z^{-1} + 0.89z^{-2}} \\ &= \frac{(4.4400 - 4.45z^{-1})(1 - z^{-1}) + 1 - z^{-5}}{(1 - 1.6z^{-1} + 0.89z^{-2})(1 - z^{-1})} \\ &= \frac{5.4400 - 8.8900z^{-1} + 4.4500z^{-2} - z^{-5}}{(1 - 1.6z^{-1} + 0.89z^{-2})(1 - z^{-1})} \end{aligned}$$

Using matlabs “residuez”, we obtain the expansion

$$Y_{ul}(z) = \frac{-0.0362 - 2.1684j}{1 - (0.8000 + 0.5000j)z^{-1}} + \frac{-0.0362 + 2.1684j}{1 - (0.8000 - 0.5000j)z^{-1}} + 5.5124 + 3.1435z^{-1} + 1.1236z^{-2}$$

Taking inverse z-transform, we obtain

$$\begin{aligned} y(n) &= [(-0.0362 - 2.1684j) \times (0.8000 + 0.5000j)^n + (-0.0362 + 2.1684j) \times (0.8000 - 0.5000j)^n]u(n) \\ &\quad + 5.5124\delta(n) + 3.1435\delta(n - 1) + 1.1236\delta(n - 2) \\ &= 2.1687e^{-1.5875j}0.9434^n e^{j0.5586n} + 2.1687e^{1.5875j}0.9434^n e^{-j0.5586n} \\ &\quad + 5.5124\delta(n) + 3.1435\delta(n - 1) + 1.1236\delta(n - 2) \\ &= 2.16870 \times .9434^n [e^{j(0.5586n - 1.5875)} + e^{-j(0.5586n - 1.5875)}] \\ &\quad + 5.5124\delta(n) + 3.1435\delta(n - 1) + 1.1236\delta(n - 2) \\ &= 4.3374 \times .9434^n \cos(0.5586n - 1.5875) \\ &\quad + 5.5124\delta(n) + 3.1435\delta(n - 1) + 1.1236\delta(n - 2) \end{aligned}$$

This function was plotted using matlab to give the following result:

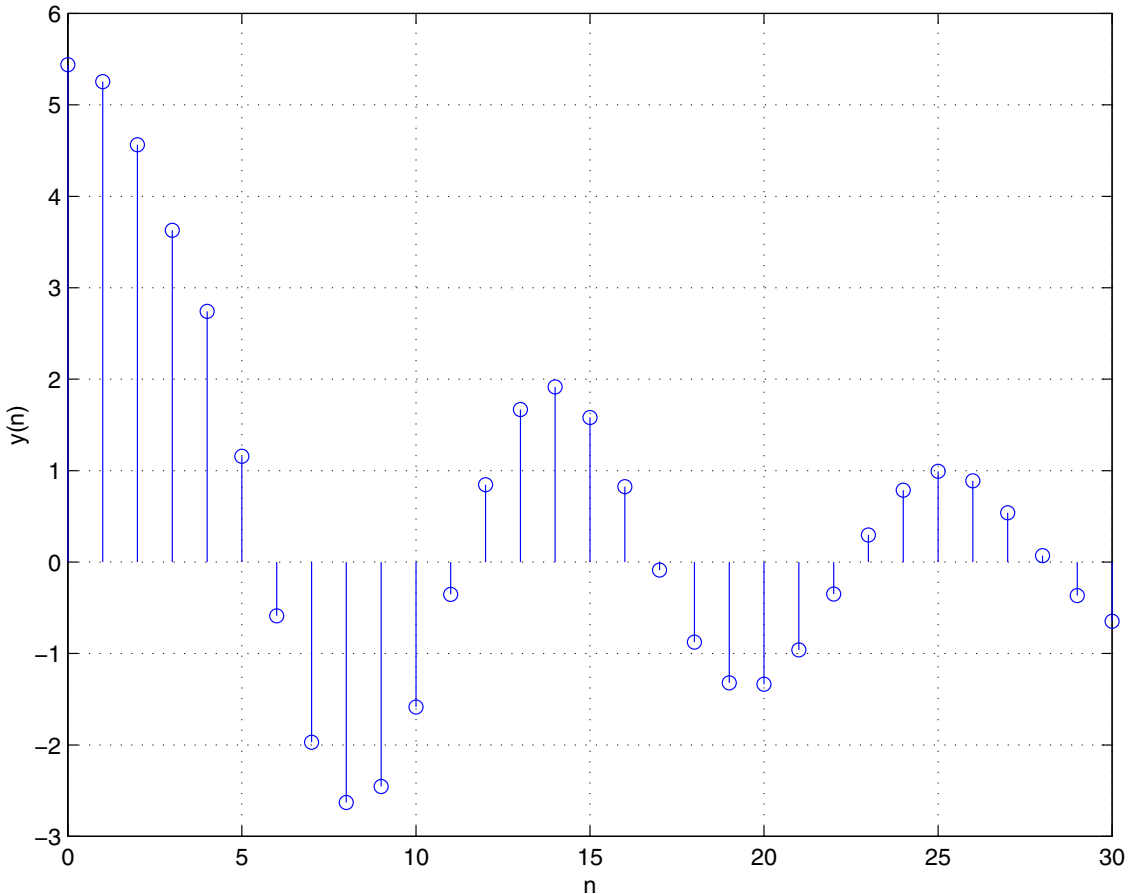

Also, this result was verified using a simulink simulation of the system as follows:

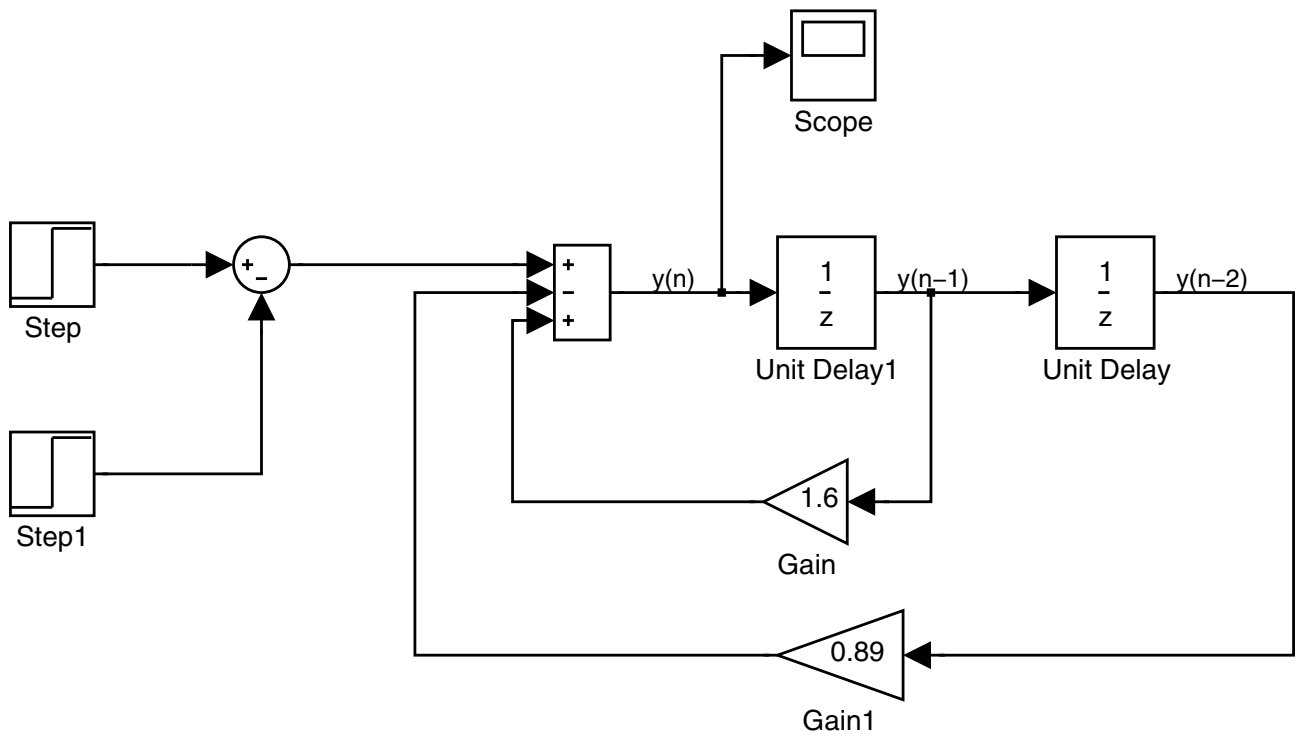

In this block diagram, the delay blocks and the step blocks all had a sample period set to 1. The block “step” had a step time of zero and the block “step1” had a step time of 5. The block “Unit Delay1” had an initial condition of 5 and the block “Unit Delay” had an initial condition of 4. The simulation was run using the “discrete (no continuous states)” solver option. This gave the following plot

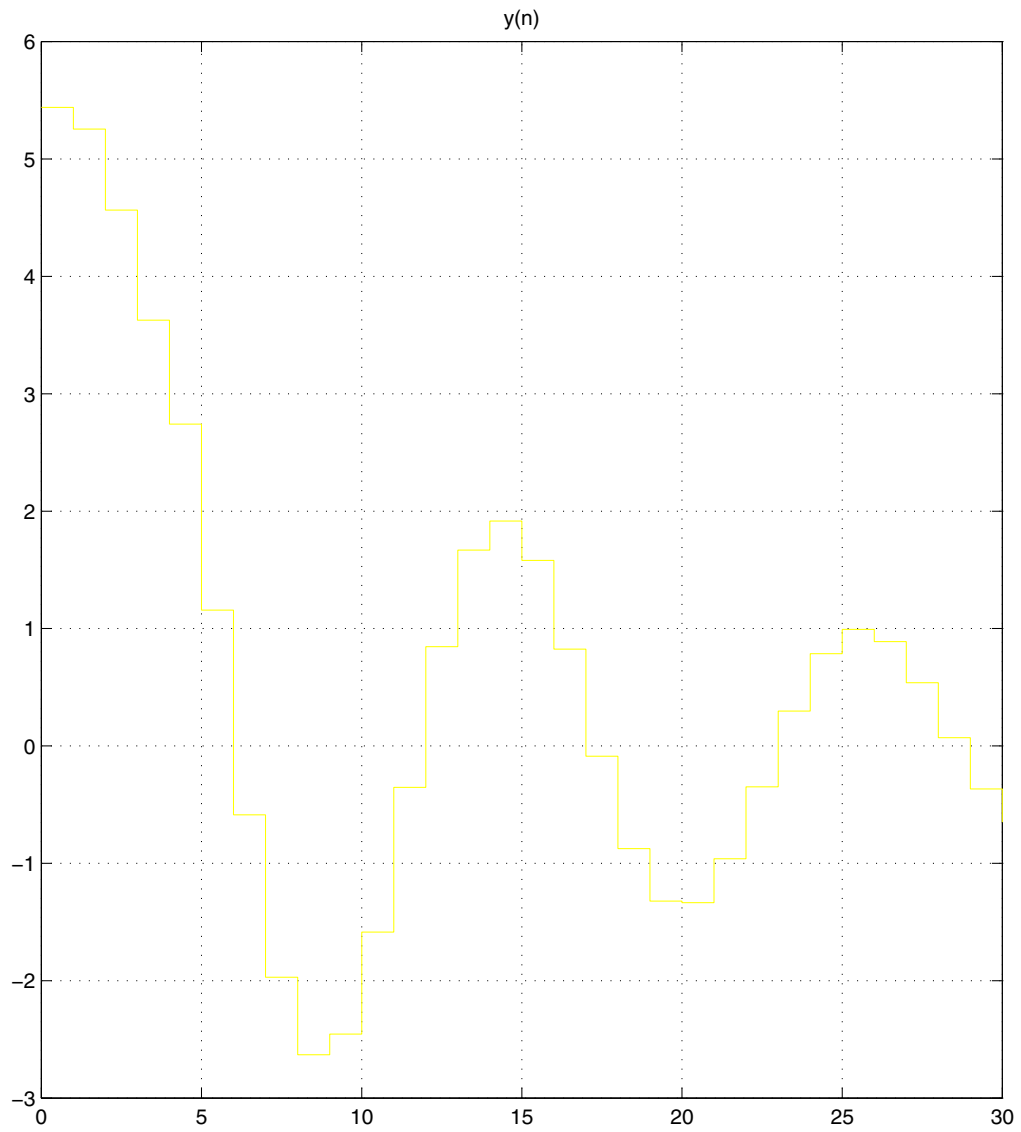

Time offset: 0

which agrees with our calculations using the unilateral z-transform.